



IRIMO

5. TORNILLOS DE BANCO

Tornillos de banco

GUÍA REDONDA

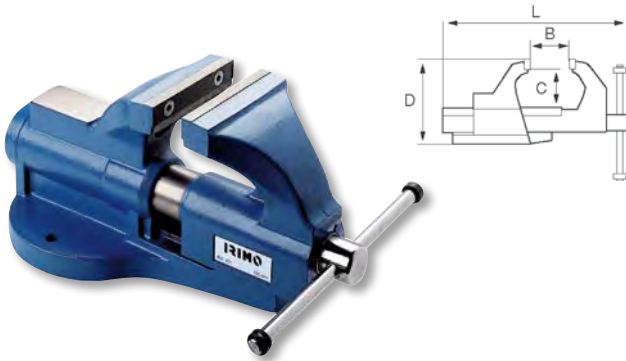

- Tornillo de banco guía redonda
- Fabricado en acero de alta calidad
- Altamente resistente
- Mordazas intercambiables
- Zona de golpeo de mayor superficie
- Husillo con rosca y palanca de giro con suave desplazamiento
- Puede ser utilizado con base giratoria

R	Icono	B mm	C mm	D mm	L mm	g	
201231	1	80	90	42	130	260	5.850
201241	1	100	110	56	166	325	11.350
201251	1	125	130	72	196	375	18.200
201261	1	150	170	80	230	430	29.700

GUÍA CUADRADA, AJUSTE REGULABLE



- Tornillo de banco guía cuadrada
- Fabricado en acero de alta calidad
- Mordazas para tubos
- Mordazas intercambiables
- Zona de golpeo de mayor superficie
- Husillo laminado con rosca y palanca con giro y desplazamiento suave
- Compatible con base giratoria
- Ajuste de guía regulable
- Apoyo de la guía en 4 superficies mecanizadas

R	Icono	B mm	C mm	D mm	L mm	g	
216041	1	100	145	50	122	325	6.497
216051	1	125	170	63	152	402	13.733
216061	1	150	230	80	182	492	20.388
216071	1	175	250	94	211	551	30.688

GUÍA CUADRADA

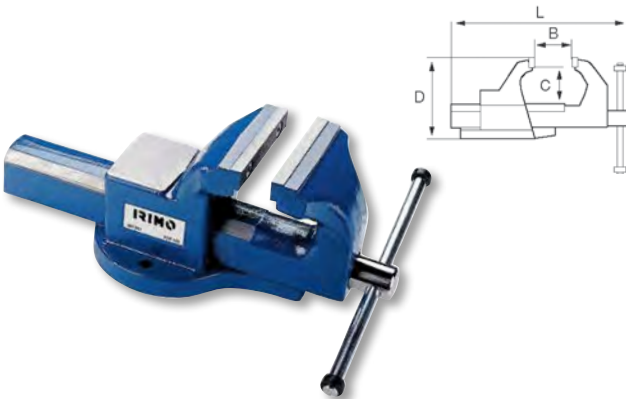

- Tornillo de banco guía cuadrada
- Fabricado en acero de alta calidad
- Alojamiento para mordazas para tubos
- Mordazas intercambiables
- Zona de golpeo de mayor superficie
- Husillo con rosca y palanca con giro suave
- Compatible con base giratoria

R	Icono	B mm	C mm	D mm	L mm	g	
207041	1	100	145	50	122	325	6.200
207051	1	125	170	63	152	402	13.200
207061	1	150	230	80	182	492	19.800
207071	1	175	250	94	211	551	30.100

GUÍA CUADRADA

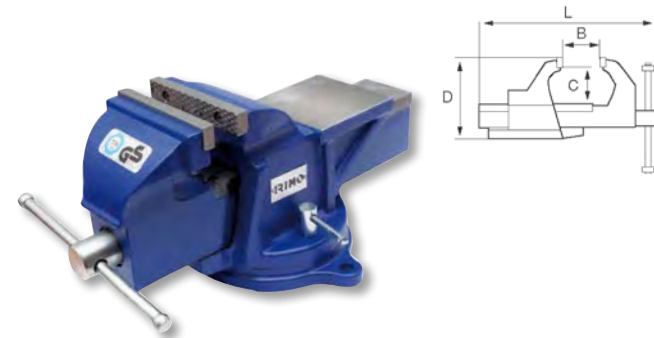

- Tornillo banco guía cuadrada
- Fundición dúctil para mayor resistencia a impactos, con características similares al acero
- Fijado con la base giratoria
- Yunque cuadrado largo
- Pin sujeción al husillo para evitar la caída de la mordaza
- Mordazas y husillos disponibles
- Certificación GS

R	Icono	B mm	C mm	D mm	L mm	g	
207-100	1	100	100	61	164	330	11.450
207-125	1	125	125	72	193	408	20.000
207-150	1	150	150	84	223	466	29.700

Repuestos

MORDAZAS DE REPUESTO

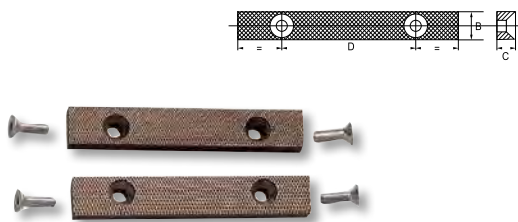

- Pareja de mordazas y tornillos para tornillo guía redonda 201

R		L mm	B mm	C mm	D mm	g
202401	1	80	15	10	55	170
202411	1	100	20	12	64	350
202421	1	125	20	12	77	450
202431	1	150	25	14	90	750

MORDAZAS DE REPUESTO

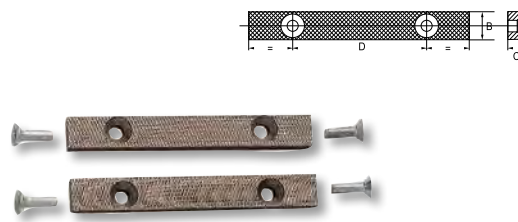

- Pareja de mordazas y tornillos para tornillo guía cuadrada 207041 / 207071 y 216

R		L mm	B mm	C mm	D mm	g
202441	1	100	15	10	64	350
202421	1	125	20	12	77	450
202451	1	150	20	12	90	750
202461	1	175	25	14	105	1.020

MORDAZAS DE REPUESTO

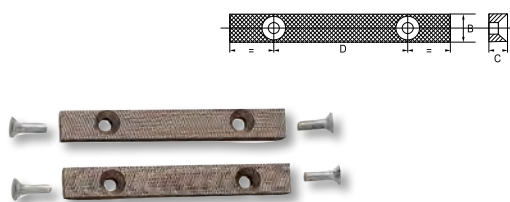

- Pareja de mordazas con tornillos para tornillo guía cuadrada 207-100 / 207-150

R		L mm	B mm	C mm	D mm	g
202-100	1	100	20	10	60	270
202-125	1	125	21	12	75	460
202-150	1	150	21	12	90	550

MORDAZAS PARA TUBO



- Pareja de mordazas de tubo y tornillos para tornillo guía cuadrada 207041 / 207071 y 216

R		L mm	Ø mm	g
206721	1	100	13,5 - 26,9	245
206741	1	125	21,3 - 76,1	436
206761	1	150 / 175	26,9 - 89,0	478

HUSILLO Y TUERCA



- Husillo y tornillo para guía redonda 201

R		L mm	L mm	g
202811	1	80	251	875
202821	1	125	317	1.400
202831	1	100	364	2.200
202841	1	150	428	3.400

HUSILLO Y TUERCA



- Husillo y tuerca para tornillo guía cuadrada 207041 / 207071 y 216

R		L mm	L mm	g
206821	1	100	287	600
206831	1	125	352	1.400
206841	1	150	432	2.200
206851	1	175	471	3.200

Repuestos

HUSILLO Y TUERCA



- Husillo y tuerca para tornillo guía cuadrada 207-100 / 207-150

R	Icono	Ø mm	L mm	g
206-100	1	100	165	560
206-125	1	125	188	920
206-150	1	150	216	1.060

Accesorios

BASE DE TORNILLO GIRATORIA

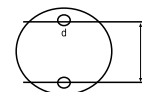

- Base giratoria para todos los modelos de guía redonda 210 y cuadrada 207041 / 207071 y 216

R	Icono	Ø mm	mm	L mm	d mm	g
201431	1	80	100	90	11	850
201451	1	100	125	115	13	1.150
201461	1	125	150	145	13	1.500
201471	1	150	175	165	17	2.500

MORDAZAS ALUMINIO DOBLE RANURADO

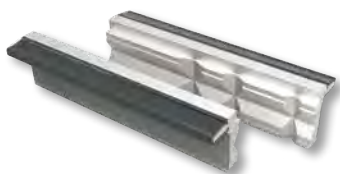

- Pareja de mordazas protectoras magnéticas: de aluminio con ranurado horizontal y vertical profundo
- Incluye un imán fuerte para unir fácilmente la mordaza en el acero

R	Icono	Ø mm	g
202561	1	100	180
202571	1	125	200
202581	1	150	220

MORDAZAS ALUMINIO RANURADAS



- Pareja de mordazas protectoras magnéticas: de aluminio con ranurado horizontal simple
- Incluye un imán fuerte para unir fácilmente la mordaza en el acero

R	Icono	Ø mm	g
202511	1	100	180
202521	1	125	200
202541	1	150	220

MORDAZAS POLIURETANO



- Pareja de mordazas protectoras magnéticas: de poliuretano con ranurado horizontal y vertical profundo
- Incluye un imán fuerte para unir fácilmente la mordaza en el acero

R	Icono	Ø mm	g
202661	1	100	150
202671	1	125	175
202681	1	150	200

MORDAZAS POLIURETANO



- Pareja de mordazas protectoras magnéticas: de poliuretano con moleteado uniforme
- Incluye un imán fuerte para unir fácilmente la mordaza en el acero

R	Icono	Ø mm	g
202761	1	100	150
202771	1	125	175
202781	1	150	200

Tornillo de sobremesa

TORNILLO DE BANCO DE SOBREMESA

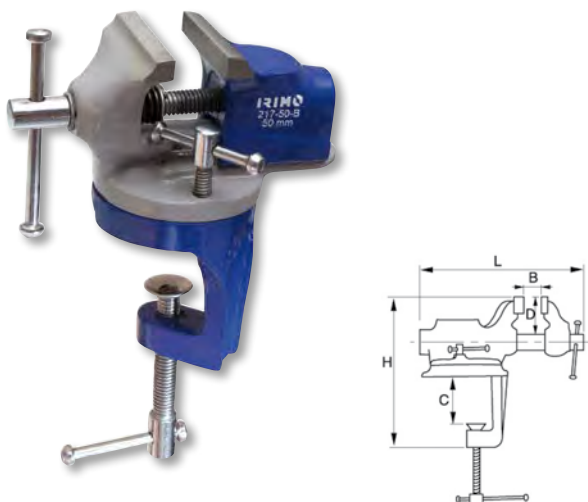

- Herramienta versatil
- Base giratoria
- Yunque acabado
- Material: hierro fundido
- En blister

Q	Icono	B mm	C mm	D mm	H mm	L mm	g
217-50-B	1	50	40	34	20	120	1.100

TORNILLO DE SOBREMESA DE GUÍA REDONDA

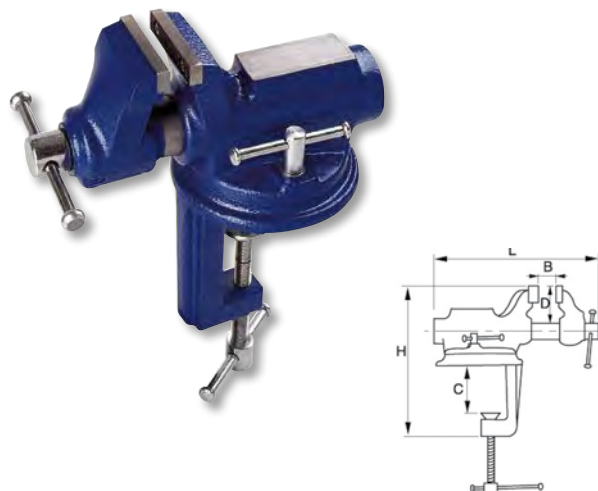

- Husillo protegido
- Giratorio
- Fundición nodular

Q	Icono	B mm	C mm	D mm	H mm	L mm	g
217161	1	63	54	76,2	47	219	4.800

Repuestos

MORDAZAS DE REPUESTO

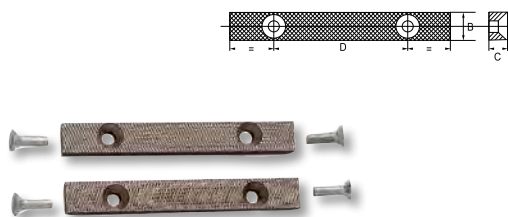

- Pareja de mordazas y tornillos para tornillo 217161

Q	Icono	B mm	C mm	D mm	g	
217261	1	63	15	7,7	40	100

HUSILLO



- Husillo de repuesto para tornillo banco 217161

Q	Icono	L mm	g	
217271	1	63	201,5	210

Aprietos de émbolo

APRIETO MANGO DE MADERA

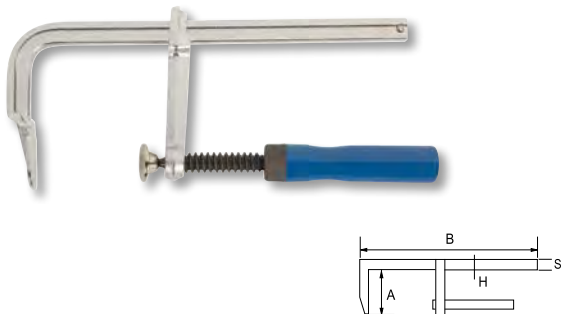

- Aprieto profesional con soporte fijo y corredizo y barra de acero galvanizada
- Mango de madera roscado para un ajuste cómodo
- Bocas forjadas que permiten una gran fuerza de forma constante

Q	Icono	A mm	B mm	HxS mm	g
258-100-2	1	60	100	15.5x7.5	450
258-120-2	1	60	120	15.5x7.5	750
258-160-2	1	80	160	15.5x7.5	900
258-200-2	10	120	200	22x10.6	1200
258-250-2	10	120	250	22x10.6	1500
258-300-2	10	120	300	22x10.6	1586

APRIETO DE 90 MM

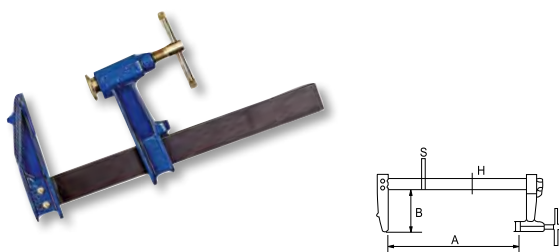

Q	Icono	A mm	B mm	HxS mm	g
256001	5	150	90	30x8	1.100
256011	5	200	90	30x8	1.200
256021	5	250	90	30x8	1.300
256031	5	300	90	30x8	1.400
256041	5	400	90	30x8	1.600

APRIETO DE 120 MM

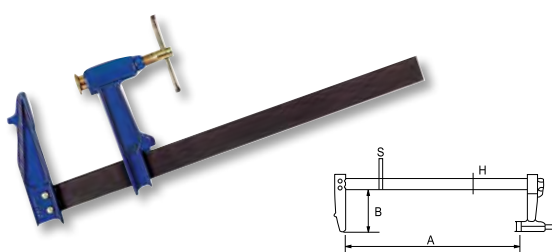

Q	Icono	A mm	B mm	HxS mm	g
256131	5	300	120	35x8	2.000
256141	5	400	120	35x8	2.200
256151	5	500	120	35x8	2.400
256161	5	600	120	35x8	2.600
256181	5	800	120	35x8	3.000
256201	5	1.000	120	35x8	3.400

APRIETO DE 150 MM

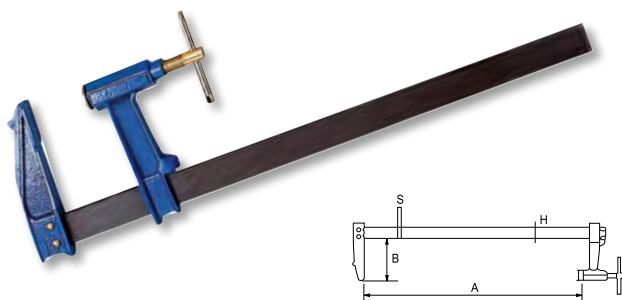

Q	Icono	A mm	B mm	HxS mm	g
256231	5	300	150	40x10	3.100
256241	5	400	150	40x10	3.400
256251	2	500	150	40x10	3.700
256261	2	600	150	40x10	4.000
256281	2	800	150	40x10	4.600
256301	2	1.000	150	40x10	5.200
256321	1	1.200	150	40x10	5.800

TORNIQUETE DE MARQUETERÍA DE 70 MM

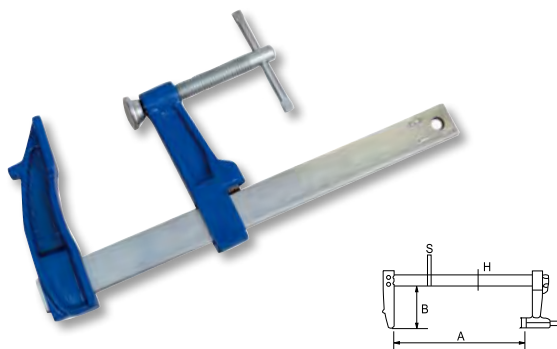

Q	Icono	A mm	B mm	HxS mm	g
255011	10	120	70	18x7	420
255021	10	150	70	18x7	450
255031	10	200	70	18x7	500
255041	10	250	70	18x7	550
255051	10	300	70	18x7	600

APRIETO EXTRA FUERTE CON MECANISMO DE CARRACA

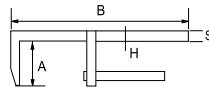

- Aprieto profesional
- Sujeción extra fuerte: 510 kg
- Cuerpo de aluminio
- Hasta 5100 Nw
- Mecanismo de carraca

QR		A mm	B mm	HxS mm	
257-200-2	10	200	140	25 x 12	986
257-300-2	10	300	140	25 x 12	1.586
257-400-2	10	400	140	25 x 12	2.286
257-500-2	10	500	140	25 x 12	2.886
257-600-2	10	600	140	25 x 12	3.286

Mordazas de ajuste rápido

MORDAZA DE AJUSTE RÁPIDO

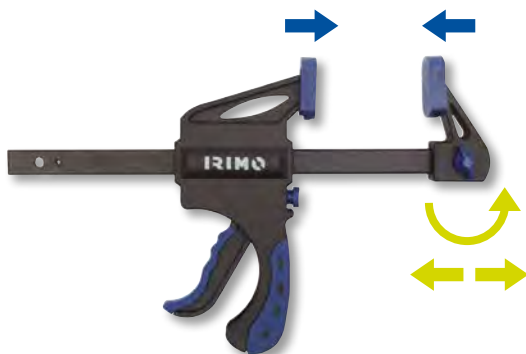

- Mordazas de alta resistencia con sistema QR
- Capacidad de sujeción: más de 60 kg
- Mordaza reversible

QR		L inch	L mm	
254-150-2	1	6"	150	487
254-300-2	6	12"	300	586
254-450-2	6	18"	450	686
254-600-2	6	24"	600	781
254-900-2	6	36"	900	980
254-1200-2	4	48"	1.200	1.165

1

2

3

4

5

6

7

8

9

10

11

12